

University „Politehnica“ Bucharest

# Simulation of a down-converter Mixer with Cadence

Supervisor:

Prof. Dr. Ing. Nițescu Miruna

Prof. Dr. Ing. Florin Constantinescu

Students:

Ing. Marin Mihai-Eugen

Marin Razvan-Cristian

May 2011

# Contents

Introduction.....	3
1. Characteristics of RF circuits.....	3
2. Simulation methods in Cadence.....	6
3. Simulation and measurement of a down-converter mixer.....	9
Conclusions.....	11
References.....	12

## **Introduction**

Modern electronic circuit technology has had a great impact on the electronics industry and has developed many new electronic circuits with both greater performance and complexity. Consequently, there is a great interest in simulation techniques for RF. In recent years a considerable amount of effort has been directed towards finding techniques by which the problem of RF circuit simulation can be approached [1-17].

Radio-frequency (RF) circuits exhibit several distinguishing characteristics that make them difficult to simulate using traditional SPICE transient analysis. The various extensions to the harmonic balance and shooting method simulation algorithms are able to exploit these characteristics to provide rapid and accurate simulation for these circuits.

### **1. Characteristics of RF circuits**

RF circuits process narrowband signals in the form of modulated carriers. Modulated carriers are characterized as having a periodic high-frequency carrier signal and a low-frequency modulation signal that acts on either the amplitude, phase, or frequency of the carrier. For example, a typical cellular telephone transmission has a 10-30 kHz modulation bandwidth riding on a 1-2 GHz carrier. In general, the modulation is arbitrary, though it is common to use a sinusoid or a simple combination of sinusoids as test signals. The ratio between the lowest frequency present in the modulation and the frequency of the carrier is a measure of the relative frequency resolution required of the simulation. General purpose circuit simulators, such as SPICE, use transient analysis to predict the nonlinear behavior of a circuit. Transient analysis is expensive when it is necessary to resolve low modulation frequencies in the presence of a high carrier frequency because the high-frequency carrier forces a small time step while a low-frequency modulation forces a long simulation interval. Passing a narrowband signal through a nonlinear circuit results in a broadband signal whose spectrum is relatively sparse, as shown in figure 1.2. In general, this spectrum consists of clusters of frequencies near the harmonics of the carrier.

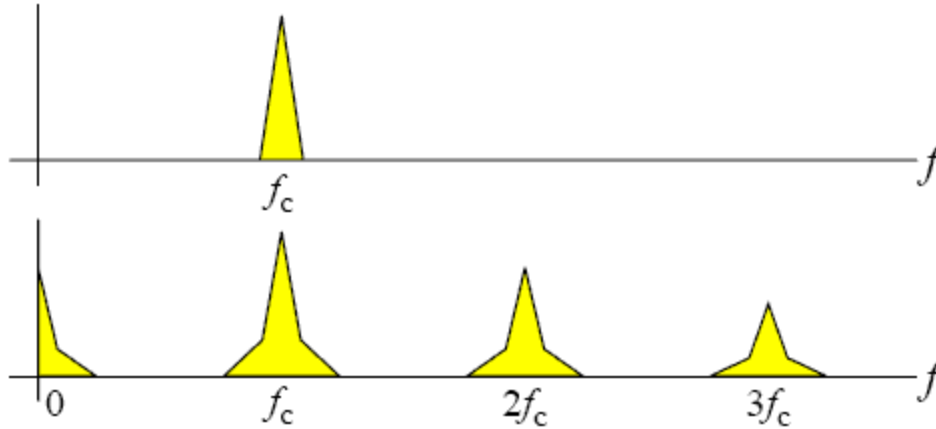

Fig. 1.1. Frequency spectrum

In fig 1.1. is presented the spectrum of a narrowband signal centered at a carrier frequency  $f_c$  before (above) and after (below) passing through a nonlinear circuit. The nonlinearity causes the signal to be replicated at multiples of the carrier, an effect referred to as harmonic distortion, and increases its bandwidth, an effect referred to as intermodulation distortion. It is possible to eliminate the effect of harmonic distortion with a band-pass filter; however the frequency of the intermodulation distortion products overlaps the frequency of the desired signal, and so cannot be completely removed with filtering.

Another important aspect of RF circuits is that they are generally designed to be as linear as possible from input to output to prevent distortion of the modulation or information signal. Some circuits, such as mixers, are designed to translate signals from one frequency to another. To do so, they are driven by an additional signal, the LO, a large periodic signal the frequency of which equals the amount of frequency translation desired. For best performance, mixers are designed to respond in a strongly nonlinear fashion to the LO. Thus, mixers behave both near-linearly (to the input) and strongly nonlinearly (to the LO). A timing or clock signal, such as the LO, is independent of the information signal, and so may be considered to be part of the circuit rather than an input to the circuit. This simple change of perspective allows the mixer to be treated as having a single input and a near-linear, though periodically time-varying, transfer function. As an example, consider a mixer made from an ideal multiplier and followed by a low-pass filter. A multiplier is nonlinear and has two inputs. Applying an LO signal of  $\cos(\omega_{LO}t)$  consumes one input and results in a transfer function of

$$v_{out}(t) = LPF\{\cos(\omega_{LO}t)v_{in}(t)\} \quad , \quad (1.1)$$

which is clearly time-varying. If the input signal is

$$v_{in}(t) = m(t) \cos(\omega_c t) \quad , \quad (1.2)$$

then

$$v_{out}(t) = LPF\{m(t) \cos(\omega_c) \cos(\omega_{LO}t)\}, \quad (1.3)$$

and

$$v_{out}(t) = m(t) \cos(\omega_c - \omega_{LO})t \quad , \quad (1.4)$$

This demonstrates that a linear periodically-varying transfer function implements frequency translation. Often we can assume that the information signal is small enough to allow the use of a linear approximation of the circuit from its input to its output. Thus, a small-signal analysis can be performed, as long as it accounts for the periodically-varying nature of the signal path, which is done by linearizing about the periodic operating point. This is the idea behind the small-signal analyses.

The semiconductor models used by RF simulators must accurately model the high-frequency small-signal behavior of the devices to accurately predict the behavior of RF circuits. BJTs have long been used in high-frequency analog circuits and their models are well suited for RF circuits. With the advent of submicron technologies, RF circuits are now being realized in standard CMOS processes [1,14], however existing MOS models are inadequate for RF applications.

RF systems are constructed primarily using four basic building blocks — amplifiers, filters, mixers, and oscillators. Amplifiers and filters are common analog blocks and are well handled by SPICE. However, mixers and oscillators are not heavily used in analog circuits and SPICE has limited ability to analyze them.

## 2. Simulation methods in Cadence

### 2.1. Periodic Steady-State Analysis with the Shooting Method

Periodic Steady-State (PSS) analysis directly computes the periodic steady-state response of a circuit. Spectre RF simulation uses an engine known as the *shooting method* [15,17] to implement PSS analysis and supports a choice of simulation engines between the shooting method and the harmonic balance method

The Periodic Steady State Analysis (PSS) in Spectre RF presents the following features:

- Directly computes the periodic steady-state response of a circuit in the time domain.
- Iterative Shooting Newton method is employed.

The shooting method is a time domain method that operates by efficiently finding an initial condition that directly results in steady state, as illustrated in figure 2.1.

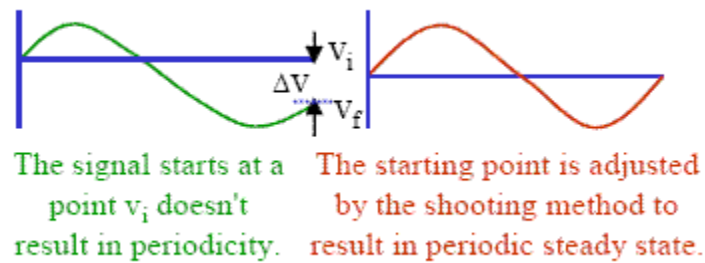

Fig. 2.1

The shooting method is an iterative method that begins with an estimation of the desired initial condition. The shooting method computes the initial condition that results in the signals being periodic as defined by  $v_f - v_i = \Delta v = 0$ . The circuit is evaluated for one period starting from the initial condition. The final state ( $v_f$ ) of the circuit is computed. The non-periodicity ( $\Delta v = v_f - v_i$ ) is used to compute a new initial condition. If the final state is a linear function of the initial state, then the new initial condition directly results in periodicity. Otherwise, additional iterations are needed.

Shooting methods require few iterations if the final state of the circuit after one period is a near-linear function of the initial state. This is generally true even for circuits that react in a strongly nonlinear fashion to large stimuli (such as the clock or local oscillator) applied to the

circuit. Since the circuit is assumed to be periodic over the shooting interval, then the stimulus must also be periodic over that same period. Typically, shooting methods need about five iterations on an average circuit. This is a strength of shooting methods over other steady-state methods such as harmonic balance. Typically, the time required to directly compute the periodic steady-state response of a circuit is about the same as the time required to compute 4 to 5 periods of the circuit's transient response. As a result, the PSS analysis is capable of directly finding the periodic steady state of very large circuits.

## **2.2. PAC analysis**

PAC analysis is a small-signal analysis like AC analysis, except the circuit is first linearized about a periodically varying operating point as opposed to a simple DC operating point. Linearizing about a periodically time-varying operating point allows transfer-functions that include frequency translation, whereas simply linearizing about a DC operating point could not because linear time-invariant circuits do not exhibit frequency translation.

Applying a periodic small-signal analysis is a two-step process.

First, the small input are ignored and a PSS analysis computes the periodic steady-state response to the remaining large signals (such as the clock or the LO). During the course of the PSS analysis, the circuit is linearized about the periodic large signal operating point.

Then the subsequent periodic small-signal analyses use this periodic operating point to predict the response of the circuit to a small sinusoid at an arbitrary frequency. Once it is known the periodic large-signal operating point, there is possible to perform any number of periodic small-signal analyses.

In order for the two-step process of applying the periodic small-signal analyses to be accurate, the input signals applied in the second step must be small enough so that the circuit does not respond to these signals in a nonlinear fashion in any significant way. This is not true for the signals applied in the first step. The only restriction on the large signals used in the initial PSS analysis is that they must be periodic. This two-step process is widely applicable because most circuits that translate frequency are designed to react in a strongly nonlinear manner to one stimulus (the LO or the clock), while at the same time they react in a nearly linear manner to other stimuli (the inputs).

Since the periodic small-signal analyses are performed on a linear representation of the circuit, the computed response is a linear function of the stimulus, regardless of the size of the stimulus. In the real circuit, the input must be small enough to avoid violating the assumptions of the small-signal analysis. However, once the circuit has been linearized, the amplitude chosen for the small stimuli is arbitrary. In this regard, the periodic small-signal analyses are similar to conventional small-signal analyses. Conventional small-signal analyses do not model frequency translation, so between any input and output there is only one frequency-dependent transfer function. However, with the periodic small-signal analyses, there are many transfer functions between any single input and output.

In practice, usually only one or two transfer functions are interesting. For example, when analyzing the down-conversion mixers found in receivers, the desired transfer function is the one that maps the input signal at the RF to the output signal at the IF, which is usually the LO minus the RF [15,17].

Another important advantage that the combination of the PSS analysis using the shooting method and the periodic small-signal analyses has over methods based on harmonic balance is that it is efficient even if the circuit is responding in a strongly nonlinear manner to the LO or the clock.



### 3. Simulation and measurement of a down-converter mixer

The measurement setup is presented in fig. 3.1, where:

- GEN – Signal generator 0-20 MHz;
- OSC – Two channel oscilloscope 100 MHz;
- CC – coaxial cable;
- M – BNC connector;
- MT – Three-way BNC connector.

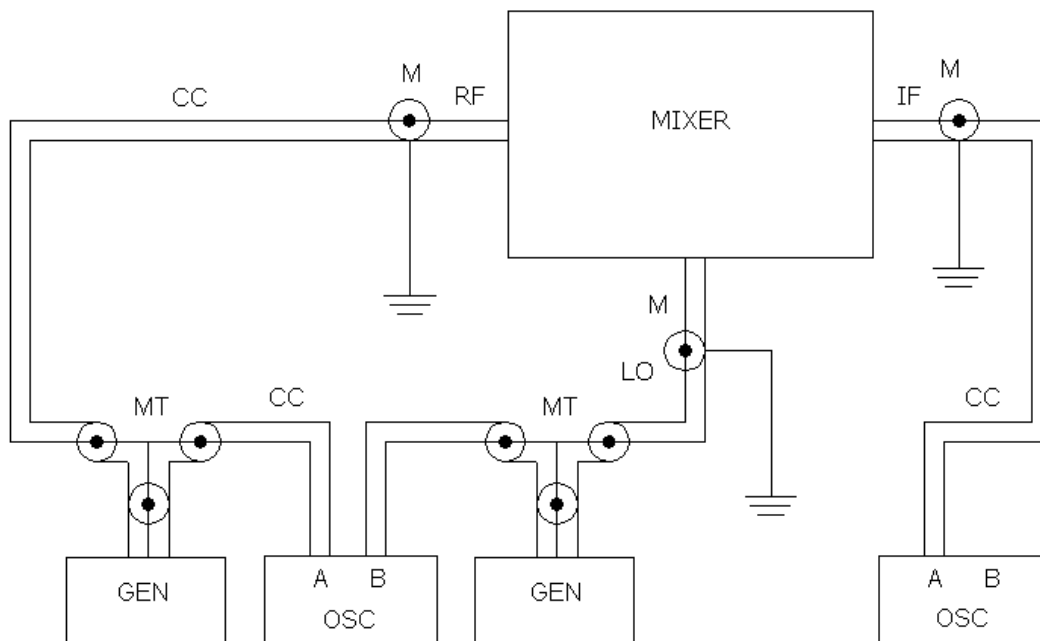

Fig. 3.1

To characterize the Voltage Conversion Gain, the output voltage at IF was measured with the oscilloscope, when LO had a constant frequency and voltage of about 10 MHz and 2V, respectively, and for the RF signal generator a near constant small signal voltage value was maintained (less than 50mV) while the frequency was modified. The results of the measurements and simulation are presented in the following.

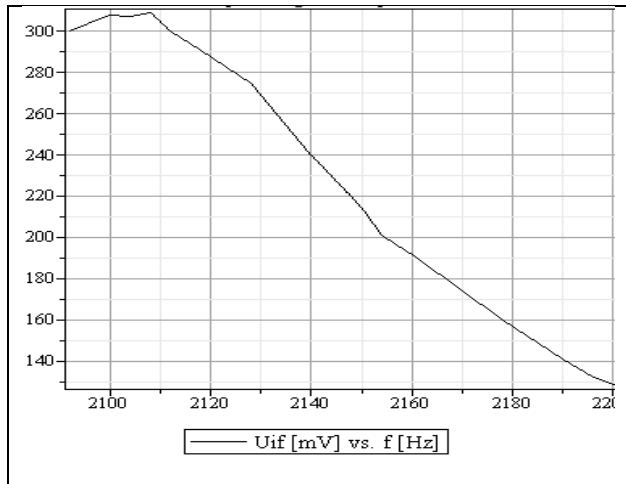

Fig 3.2. Measured V vs. f characteristic

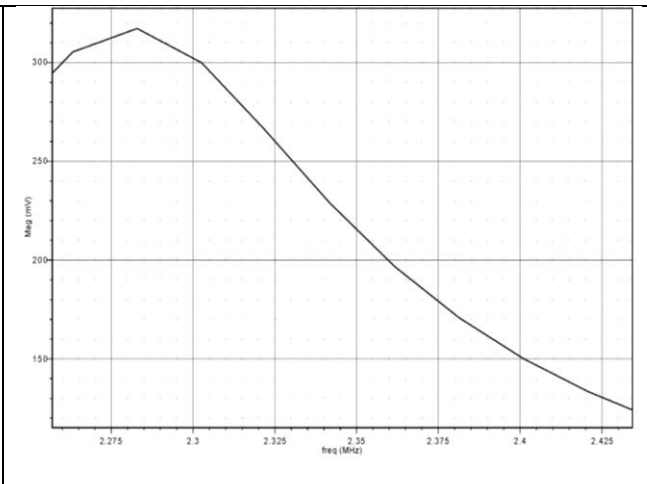

Fig 3.3 Simulated V vs. f characteristic

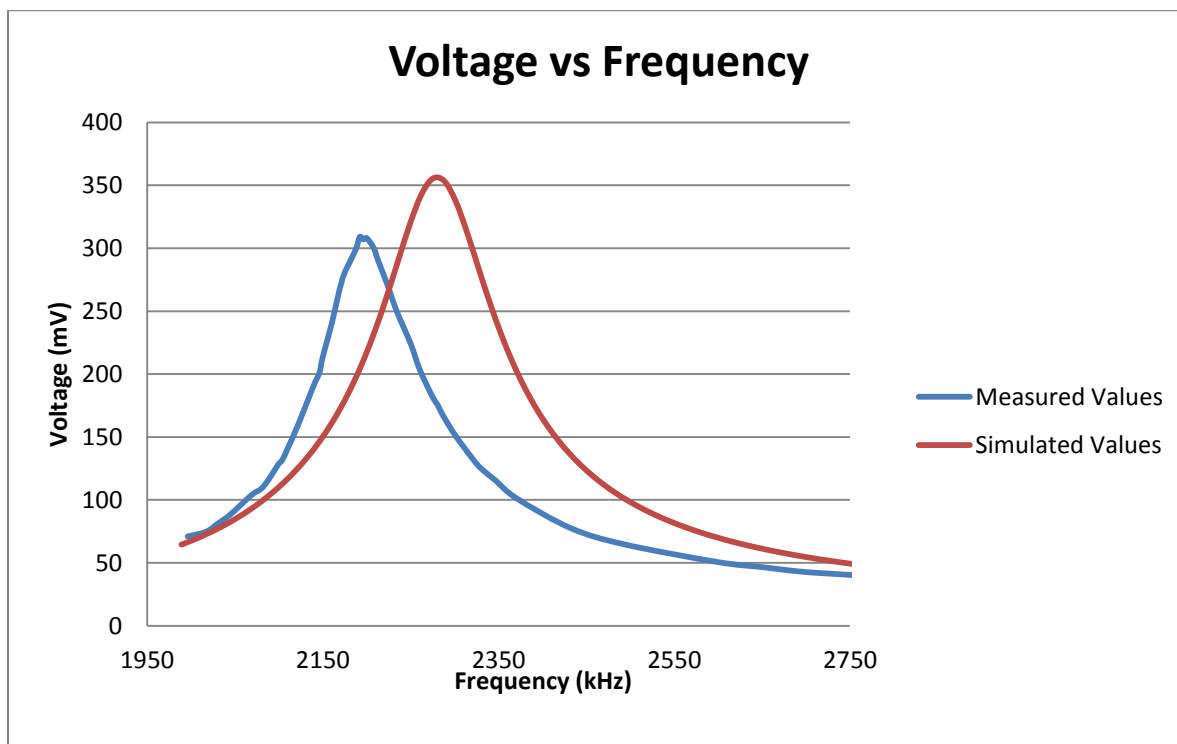

Fig. 3.4. Measured and simulated V vs. f characteristics on the same graph

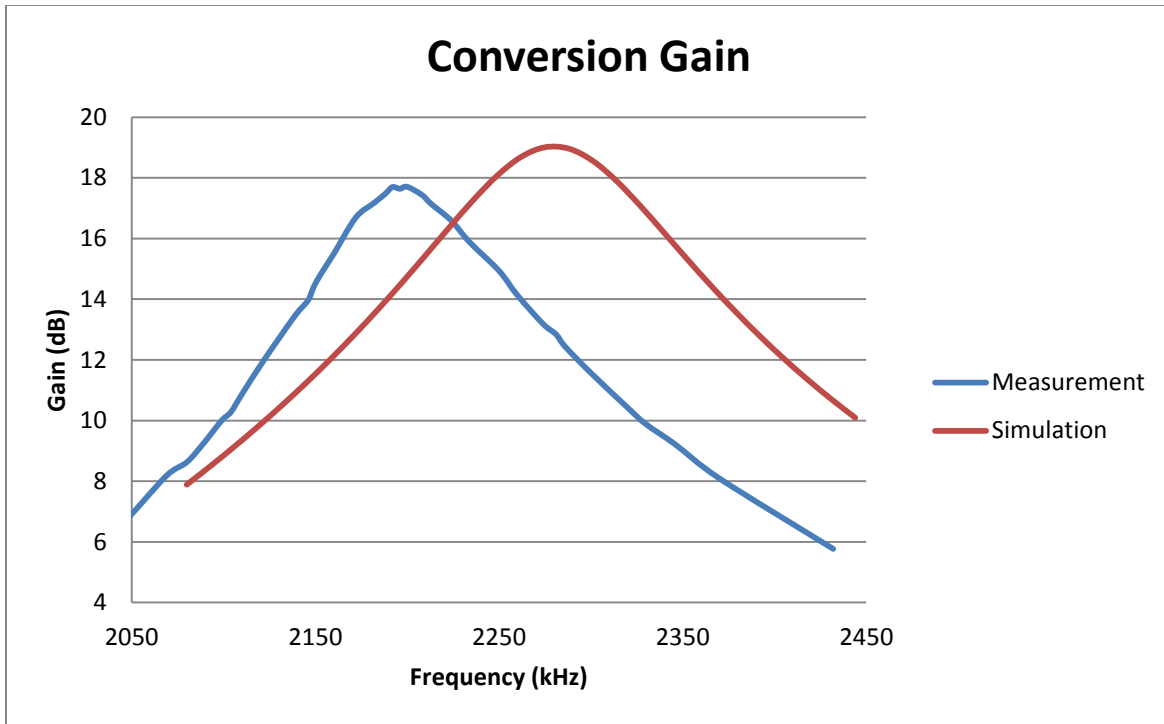

Fig. 3.5. Measured and simulated Conversion gain vs.  $f$  characteristics on the same graph

## Conclusions

The paper describes the methods used to simulate a down-conversion mixer.

A measurement setup for measuring the conversion gain is also presented.

The measured results are in concordance with the result obtained from simulations.

Therefore the simulation methods employed in this paper have proved their effectiveness.

## References

- [1] K. Kundert, Introduction to RF simulation and its application *Journal of Solid-State Circuits*, vol. 34, no. 9, September 1999.
- [2] H. G. Brachtendorf, G. Welsch, R. Laur, A. Bunse-Gerstner, “Numerical steady state analysis of electronic circuits driven by multi-tone signals”, *Electrical Engineering (Springer-Verlag)*, 79 (1996) pp. 103-112.
- [3] F. Constantinescu, M. Nitescu, “A multi-rate method for finding the periodic steady-state of nonlinear high-speed circuits”, *Proceedings of ECCTD '99*, p. 767-770.
- [4] F. Constantinescu, M. Nitescu, and C. V. Marin, A glimpse into some aspects of nonlinear circuit analysis, Simpozionul Național de Electrotehnică Teoretică (National Symposium of Theoretical Electrical Engineering), 12-14 Mai 2005, București
- [5] Constantinescu F., Nitescu M., Marin C.V., Some remarks on nonlinear circuit analysis, *Revue Roumaine des Sciences Technique – Electrotechnique et Energetique*, Tome 51, 3, p.293-302, Bucarest, 2006.
- [6] Florin Constantinescu, Miruna Nitescu, Marin C.V., Two-rate Computation of the Periodic Steady-state in Nonlinear RF-IC Circuits, , Proc. of the European Conference on Intelligent Technologies ECIT 2000, Iasi 25-28 sept. 2000-10-23.
- [7] Fl. Constantinescu, Miruna Nitescu, C.V. Marin.. Finding Periodic Steady State for Strongly Nonlinear RF-IC Circuits using Shooting by Exponential Extrapolation, pg. 326-330 Proc. Of ICCSC'02, 26-28 June, 2002, Sankt-Petersburg, Russia.
- [8] Constantinescu F., Nitescu M., Marin C. V., New results in two-rate analysis of RF-IC circuits, Symposium on Advanced Topics in Electrical Engineering (ATEE 2000), Bucuresti, Dec. 8, 2000, pag. 25-30.
- [9] F. Constantinescu, A.-G. Gheorghe, M. Nitescu, Large signal analysis of RF circuits – an overview, Proceedings of the Conference on Advanced Topics in Electrical Engineering (ATEE 2006), Politehnica University, Bucharest, Romania, November 24-25, 2006.
- [10] F. Constantinescu, A. Ionescu, M. Nitescu, „A new extrapolation method for fast finding of the periodic steady state in nonlinear circuits”; Simpozion on nonlinear theory and application (NOLTA '98), Crans – Montana Switserland, sept 14-17, 1998.
- [11] F. Constantinescu, M. Nitescu, C. V. Marin, “A glimpse into some aspects of nonlinear circuit analysis”, *Rev. Roum. Sci. Techn., Ser. Electrotechn. et Energ.*, 2006.
- [12] F. Constantinescu, M. Nitescu, C.V. Marin, SPICE models for two-rate computation of the periodic steady state in nonlinear RF circuits, Proceedings of NOLTA 2000, pag. 213-216.
- [13] A. G. Gheorghe, „Metode noi de analiză a circuitelor neliniare de RF”, Teza de doctorat, UPB, Bucuresti, 2009.
- [14] \*\*\* SPECTRE RF – Theory,  
<http://www-eel.upc.es/rfcs/Material/Cadence%202004/spectreRFTheory.pdf>
- [15] \*\*\* Mixer Design Using **SpectreRF**. June 2004. 5. Product Version 5.0,  
[http://www.ek.isy.liu.se/~jdab/SpectreRF\\_Mixer533AN.pdf](http://www.ek.isy.liu.se/~jdab/SpectreRF_Mixer533AN.pdf)
- [16] \*\*\* Virtuoso Spectre Circuit Simulator RF, Analysis User Guide, Product Version 6.2, June 2007,  
[http://www.seas.gwu.edu/~vlsi/ece218/SPRING/reference/manual\\_cadence\\_spectreRF.pdf](http://www.seas.gwu.edu/~vlsi/ece218/SPRING/reference/manual_cadence_spectreRF.pdf).
- [17] A User's Guide to Envelope Following, Analysis Using SpectreRF, Product Version 6.1.1, April 2007, [http://www.cadence.com/rl/Resources/white\\_papers/env.pdf](http://www.cadence.com/rl/Resources/white_papers/env.pdf)